

# European Journal of Psychology of Education

A Journal of Education and Development

ISSN: 0256-2928 (Print) 1878-5174 (Online)

## **A dialogical self approach to the conceptualisation of teacher-inquirer identity**

Antoni Badia<sup>a</sup>, Eva Liesa<sup>b</sup>, Lorena Becerril<sup>a</sup> and Paula Mayoral<sup>b</sup>

<sup>a</sup> Faculty of Psychology and Educational Sciences, Universitat Oberta de Catalunya, Barcelona, Spain

<sup>b</sup> Department of Psychology, Ramon Llull University, Barcelona, Spain

### **ORCID:**

Antoni Badia <http://orcid.org/0000-0003-1294-8061>

Eva Liesa: <https://orcid.org/0000-0002-9533-3689>

Lorena Becerril: <https://orcid.org/0000-0001-6357-1300>

Paula Mayoral: <https://orcid.org/0000-0002-8667-0560>

Contact: Antoni Badia. Email: [tbadia@uoc.edu](mailto:tbadia@uoc.edu)

Address of correspondence: Rambla del Poblenou, 156, Barcelona 08018, Spain

### **Abstract**

Over the last thirty years, a substantial number of publications have attempted to conceptualise the ways in which teachers carry out inquiries in order to affect changes in educational practice. A number of different psychological models have been applied to the study of teachers' activities as inquirers, including models focusing on teachers' professional development, socio-constructivist models of teacher thinking and teacher learning models. The aim of this article is to provide a more comprehensive, in-depth conceptualisation of teacher inquiry by using the central concepts of dialogical self theory and by establishing a closer relationship between teacher identity and individual teacher inquiry. We begin by defining the notions of teacher inquiry and teacher

identity, and then go on to describe dialogical-self theory and how this approach can be applied to the description of the teacher-inquirer identity. We conclude this position paper with a detailed example in the form of a single case study illustrating how teachers' identity as inquirers can be analysed, and we offer some reflexions about potential future research in this new area of study.

**Keywords:** Dialogical self; I-position; Teacher identity; Teacher-inquirer identity.

## 1. Introduction

This aim of this position paper is to offer a more comprehensive understanding of the conceptualization of the notion of *teacher-inquirer identity* using dialogical self theory. To meet this general objective, we consider that it will be necessary to attain the four specific objectives that follow: 1) To define *teacher inquiry* and teacher identity, 2) To identify a range of potential psychological components of teacher-inquirer identity; 3) To define *teacher-inquirer identity* using *dialogical self theory*, and 4) To give a practical example of how teacher-inquirer identity can be described in a single case study.

The notion of teacher-inquirer identity has important implications for research, policy and teacher education. Research examining the notion of *teacher-inquirer identity* has the potential to open the door to the study of teacher inquiry from new psychological perspectives. This would contribute to the current body of knowledge in the field of study of teacher identity, employing a novel approach based on the theory of dialogical self. In turn, the new knowledge that will emerge from the study of this topic will be useful in the design and implementation of educational reforms and innovations aimed at making schools more successful, and it will inform efforts to improve existing teacher development and teacher learning programs related to teacher inquiry.

In the following section, we will present a conceptual framework with respect to teacher-inquirer identity in light of dialogical self theory. To achieve this aim, we will first focus on giving a definition of *teacher inquiry*. Next, we will define the notion of *teacher-inquirer identity* in terms coherent with the theory of dialogical self. We will go on to sketch out the connections between this notion and the existing psychological concepts that are closely related to teacher inquiry. Finally, we will use this theoretical

framework to describe the inquirer identity of a real teacher involved in the process of systematic educational innovation.

## **2. Teacher inquiry and teacher identity**

The aim of this section is to provide a more comprehensive, in-depth conceptualisation of teacher inquiry, defining inquiry as both a process and a stance, as well as to draw the connections between teacher inquiry and teacher identity.

Earlier approaches to defining teacher inquiry have mainly focused on the pedagogical transformation of teaching practice, and scholars have tended to view inquiry as a process which includes a series of activities or actions to be completed. For example, in some of the first conceptualisations of inquiry in education, Dewey (1986) characterised inquiry as a specific process of reflection and problem solving to improve teaching practice, while Schön (1991) posed an idea of teachers' inquiry processes focusing on how teachers reflect both during and after the implementation of their teaching practice.

Subsequent contributions added new features to the definition of teacher inquiry as a process. For example, Ermeling (2010) described teacher inquiry as a collaborative process among teachers who identify and define specific instructional problems within the local context, plan and implement instructional solutions connecting theory to action, utilise evidence to drive analysis, reflection and make conclusions, and work toward measurable improvements in teaching and learning.

In contrast, the teacher inquiry perspective has in the past mainly focused on how to ensure the effectiveness of teachers' professional learning and development through inquiry. Studies of this issue have tended to view inquiry as a given teacher's set of assets, including, for example, his or her knowledge and beliefs about teaching practice (Day, 1999) and the teacher's stance with regard to inquiry (Cochran-Smith & Lytle, 1999). In a later contribution, a teacher's stance was defined as a mindset or a critical habit of mind that leads a teacher to search for ways to obtain valuable insights into their professional practice (Cochran-Smith & Lytle, 2009).

Recent perspectives assumed both dimensions of teacher inquiry, and define teacher inquiry as teachers' search for improvement of both knowledge and classroom

instruction through the systematic and intentional study of teaching practice (Timperley, Kaser, & Halbert, 2014). Teacher inquiry can be considered a teacher stance consisting of a specific teacher's knowledge, skills and attitudes. It also involves a process which leads to educational innovation and supports educational change, as a result of the development of new teaching approaches that differ from traditional teaching and learning processes.

Recently, relevant research contributions have pointed to a close relationship between teacher inquiry (in the context of pedagogical innovation) and the notion of teacher professional identity. For example, Avidou-Ungar and Forkosh-Baruch (2018) studied some components of teacher identity with regard to pedagogical innovation, and Chua, Liu and Chia (2018) identified the knowledge, skills, and values associated with the kind of strong teacher identity which is required to carry out professional practice and inquiry.

Teacher identity has become a central conceptual construct over the last twenty years in the study of how teachers act, work and learn (Akkerman & Meijer, 2011). It remains challenging to offer a precise definition of teacher identity (Beauchamp & Thomas, 2009) but, in a general sense, we can define teacher identity as a concept used to describe what a teacher thinks and what a teacher does in the context of his or her professional status at in a given time and place (Badia & Iglesias, 2019).

Research focused on this theoretical construct frequently seeks to show how some of the teachers' main characteristics, such as their personal knowledge (Beijaard, Verloop, & Vermunt, 2000) and practical theories (Stenberg, Karlsson, Pitkaniemi, & Maaranen, 2014), form a part of the broader notion of teacher identity. In the next section, we will identify some of the potential psychological components of teacher identity, all of which researchers have associated with teacher's inquiry activity in current research.

### **3. Components of teacher-inquirer identity**

The aim of this section is to characterise the concept of teacher-inquirer identity in an attempt to describe the various components at work, mainly when teachers deal with educational innovation. To our knowledge, while some previous studies have identified several a range of components of teacher identity, prior to this work, no researches have

studied teacher-inquirer identity. The academic contributions detailed below were selected because of their academic relevance and recentness and because they were based on empirical data.

Prior researchers have identified a number of different underlying purposes of inquiry within teaching practice. The purpose of a teacher's inquiry is defined here as the goal, or the primary motivation, that drives him or her to take the initiative or participate in an inquiry activity. Three different (but not mutually exclusive) purposes for teachers' inquiry can be identified. The first of these purposes is a desire to transform teaching practice, for example by using the Spirals of Inquiry (Kaser & Halbert, 2014) or a cycle of action research (Mertler, 2012). The second purpose for teacher inquiry is to promote professional development and teacher learning (Day, 1999), as well as to gain a better understanding of their classroom, school and community teaching practice. The third purpose is to build upon existing educational knowledge. Teachers engaged in educational research can use research knowledge, methods and tools to become creators of knowledge (Cochran-Smith & Little, 2009).

Teachers' agency is a concept that can be used to reflect the degree to which teachers can achieve their inquiring purposes. Teachers' agency in carrying out inquiry activities is defined here as the extent of their power and feelings of control with regard to the decisions, choices and actions they make as part of their work, and the degree to which these choices are based on their own goals, interests and motivations (Vähäsantanen, 2015). Teachers' agency can be understood as a continuum that ranges from low to high teacher autonomy while performing inquiry activities. By way of example, inquiry processes aimed at educational reform may be carried out by teachers conducting action research with a high level of teacher agency (Somekh & Zeichner, 2009); conversely, teacher agency can clearly be constrained in the new reform context (Lasky, 2005).

The notion of teachers' agency has been used in several studies related to educational innovation. For example, Vähäsantanen (2015) distinguished between social and individual teacher agency resources and found significant differences in teachers' temporal manifestations of agency, regarding their work (ranging from weak to strong agency), their involvement with reform (from reserved to progressive agency), and the negotiation of their professional identity (from maintainable to transformative agency).

The author also proposed an agency-centred approach as a way of supporting educational transformation and teachers' identity negotiation.

Another relevant component of teacher identity consists of knowledge of what inquiring teachers need to know. In broad terms, Lunenberg, Ponte, and Van de Ven (2007) described a number of types of teachers' conceptual knowledge connected to research, focusing on knowledge that is useful to enquiring practitioners. They argued that teachers should be aware of the benefits of teacher-conducted research, the kind of topics that are suitable for research, the process for conducting research, the quality criteria in their own research and the communication of their research to their colleagues.

Elsewhere, Brause and Mayher (1991) identified eight types of procedural knowledge possessed by teachers: 1) Generating and testing hypotheses, and critiquing educational practice; 2) Reading and understanding hypothesis testing research; 3) Reading hypothesis-generating research; 4) Finding and framing questions; 5) Collecting and analysing classroom data in theory and in practice; 6) Testing hypotheses in your classroom; 7) Hypothesis studies in your classroom; and 8) Concluding and beginning. More recently, Konstantinidis and Badia (2019) identified eight teacher competencies included in the inquiry process, which they called scanning for learning problems, focusing on a problem or topic, understanding the topic, exploring existing educational practices connected to the topic, planning an educational innovation, implementing the plan, evaluating students' learning outcomes, reflecting on the experience, writing a report, and presenting results and conclusions. Overall, this procedural knowledge may be applied by teachers wishing to carry out different kinds of inquiry belonging to various inquiry models, such as three-layer cycles of inquiry (Butler & Schnellert, 2012), the spiral of inquiry (Kaser & Halbert, 2014) and professional learning through collaborative inquiry (DeLuca, Bolden, & Chan, 2017).

Avidov-Ungar and Forkosh-Baruch (2018), using the term of *being teacher*, revealed the importance of teachers' metacognitive knowledge when a teacher's orientation towards his inner-self and his perception of his/her professional identity is placed at the centre of the inquiry process. This self-understanding includes, among other things, an understanding of the need to change teaching methods, to refer to students in a different

manner, to perceive teaching in a more systemic manner, to acquire relevant professional knowledge and personal experience in pedagogical innovation, and to enhance one's ability to adapt to change.

Meanwhile, other contributions have placed teacher's self-regulation activities at the centre of teacher inquiry processes. Butler and Schnellert (2012) proposed a conceptual framework for teacher inquiry informed by a socio-constructivist model of self-regulated learning. According to these authors, teacher inquiry involves a recursive cycle of goal-directed activities and four overall processes: 1) planning actions; 2) enacting strategies; 3) monitoring outcomes; and 4) adjusting and revising goals or approaches to better achieve the desired outcomes. These four self-regulation steps can be taken at three different levels of inquiry: student-level inquiry, practice-level inquiry and teacher learning inquiry. Additionally, teachers' coregulation should be placed at the core of the collaborative community inquiry of teachers (Hadwin & Järvelä, 2011).

Several contributions include the previous types of inquiring teacher's knowledge of different comprehensive concepts. For example, Zeichner (2003) and Byman *et al.* (2009) define teachers' pedagogical thinking as the inquiring way in which teachers apply specific concepts and skills to solve daily pedagogical problems, to make pedagogical decisions and to provide justification. In the same vein, Day (1999) placed Dewey's conception of teachers' reflection, which includes the notions of reflection-in-action and reflection-on-action, at the core of the *reflective practitioner's* activity.

Teachers' sense-making process with regard to innovation is another component of teacher-inquirer identity. According to Ketelaar, Koopman, Den Brok, Beijaard and Boshuizen (2014), sense-making is an "active cognitive and emotional process in which teachers attempt to relate the information derived from the innovation to their existing knowledge, beliefs, and experiences [...]. This process is dynamic, as teachers use their own identity or frame of reference as a lens to make sense of the innovation [...], but at the same time, their identity or frame of reference can change in the process" (p. 316).

On an individual level, a teacher can experience different degrees of congruence between their beliefs and values about innovation and the innovation situations they encounter. Depending on the extent to which they feel their values are reflected, they

will be more or less likely to be enthusiastic about this innovation. On a social level, it is crucial to comprehend which strategies teachers use to share sense-making in order to construct a collective understanding of educational reform (Pyhältö, Pietarinen, & Soini, 2018).

A teacher's attitude toward a given educational innovation may manifest itself through a feeling of ownership of the innovation. This, in turn, can influence his or her positioning with regard to this innovation (Ketelaar et al., 2014). A teacher's feeling of ownership reflects the degree to which he or she supports the underlying idea of a given innovative practice. Teachers with high levels of ownership have a feeling of pride about the innovation, feel an urge and a need to make changes in their practice, are willing to invest their time and energy in the innovation, and tend to express identification with it, for example by communicating their individual experiences to colleagues. As a result, educational innovation can become a part of the teacher's professional identity and may contribute to its sustainability. A teacher's feeling of ownership can be analysed on an individual level, but its impact can also be examined on a social level. For example, Schaap and Bruijn (2018) analysed the development of professional learning communities within schools involved in a more significant innovation project and found that ownership had a real impact on the development of a community of inquiring teachers.

Finally, Avidov-Ungar and Forkosh-Baruch (2018) also revealed the importance of a teacher's inclination to react to the institutional and social context in which the inquiring process takes place, mainly in a possessive and controlling manner. An inquiring teacher needs to control elements outside the individual in order to establish status and carry out innovation. Three of the primary needs that must be met if a teacher is to pursue inquiry are emotional, technical and pedagogical support from the education system, the school and his or her colleagues.

A complete conceptualisation of teacher identity, including a description of components of teacher identity that might be related to inquiry activities, might be accomplished via a psychological approach that allows us to study teacher-inquirer identity using a single unit of analysis. This overall concept should encompass all the components described



above, whether they belong to the intrapsychological or the interpsychological dimension of teacher identity.

#### **4. A dialogical self approach to conceptualise teacher-inquirer identity**

The theory of the dialogical self in psychology (Meijers & Hermans, 2018) offers an in-depth way to conceptualise how teacher-inquirer identity. This theory is particularly valuable because it allows us to study both the intrapsychological dimension (teachers' knowledge and cognition regarding inquiry) and the interpsychological (teachers' actions and social interaction regarding inquiry) dimension of teacher inquiry. It also allows us to collect teachers' voices and provides us with a detailed overview of how a teacher gives meaning to different purposes, functions and teaching activities related to teacher inquiry.

According to dialogical self theory, human beings are seen as having dialogical selves because they understand and explain the world significantly, giving meaning to human thought, human acts and themselves through language. On the individual level, the dialogical self considers a personal space of negotiation in which every person converts all voices – their own voices and those of others – into a meaningful understanding of the world (Hermans, 2001). In this intra-psychological negotiated space, teachers develop inner speech processes to give meaning to themselves and their professional practice.

Some relevant contributions have shown that dialogical self theory is an appropriate way to conceptualise teacher identity (Assen, Koops, Meijers, Otting, & Poell, 2018) and teacher-researcher identity (Taylor, 2017). Based on this approach, teacher-inquirer identity should be considered as the ongoing process through which a given teacher comes to self-understanding as he or she carries out inquiry activities. A teacher's identity is configured by a set of different I-positions related to the inquiry. Each I-position is a different manifestation of the teacher's identity in the personal or public space and at a specific time and place. These positions emerge by means of reaction to pedagogical innovation experiences. This part of the teacher's broader professional identity plays a fundamental role in how the teacher actively positions him- or herself with regard to innovation, resulting in the maintenance or alteration of a teacher's identity (Ketelaar et al., 2014).

A teacher's I-position within his or her teacher-inquirer identity is a composite term that encompasses two elements: the teacher's *position* and the teacher's *I* (Hermans, 2015). In an abstract sense, a teacher holds a *position* when they perform a specific professional function in the context of pedagogical innovation. In real scenarios, for example, in a specific school, a teacher's position will be considered a *teacher's status function* (Searle, 2010). This status function is the institutional position a teacher exercises when carrying out his or her professional activity to achieve some specific inquiring purpose, in accordance with his or her status in the institution. A teacher's set of status functions regarding a pedagogical innovation may not correspond with the set of roles assigned to the teacher by the educational administration, because the teacher's status functions reflect the way the teacher assumes a set of functions in a specific institution, rather than the roles imposed upon the teacher.

The term teacher's *I* refers to a subject-position, a first-person perspective from which the teacher interprets and carries out each status function related to inquiring processes. The *I* provides the teacher with a sense of personal initiative, and it might include specific conceptual categories which help the teacher to describe his or her own inquirer identity. These categories might include things like knowledge, beliefs, attitudes, agency, ownership and sense-making, among other things. In a real setting like a school, a teacher's inquiry I-position is the way of speaking and thinking that can be invoked when the teacher adopts a particular well-established position (status function) in relation to pedagogical innovation.

Some of the functions typically carried out by teachers through processes of inquiry are related to reflection and evaluation of their teaching practices, as well as their efforts to improve these practices (Hardy, 2016). When carrying out these functions, a teacher may activate different I-positions, depending on how they make sense of the functions (Schmidt & Datnowb, 2005) and on their perception of ownership during the process (Ketelaar et al., 2014). The set of I-positions that a teacher or a group of teachers hold when effecting processes of inquiry together make up their inquirer teacher identity or identities. In other words, teacher-inquirer identity can be defined, on an individual level, as the set of I-positions a teacher holds when he or she directly participates in the

individual social processes of performing professional and collaborative inquiry activities.

Because each teacher's inquirer I-position will be considered a 'voiced' position, a teacher's voice about a pedagogical innovation expresses many interrelated meanings (e.g., concepts, ideas, beliefs, approaches, procedures and emotions, among others) and represents a particular way of thinking and acting in connection with an aspect of the new teaching and learning approaches he or she wants to implement (Akkerman & Meijer, 2011).

In an individual dimension, a single teacher's various I-positions with regard to a pedagogical innovation can complement and support each other, coming together in combinations of I-positions. In the context of pedagogical innovation, the combination of a specific set of a teacher's I-positions related to this inquiring activity can be understood as this teacher's repertoire of inquiry-related I-positions (Hermans, 2006). An inquiring I-position repertoire is not just an agglomeration of separate I-positions, but rather an organised, hierarchical and dynamic system that allows the teacher to conduct the inquiring activity during the pedagogical innovation experience.

## **5. Characterising teacher-inquirer identity. A methodological example**

### **Method: A single case-study**

We will use the theoretical framework described above as a framework to study teacher-inquirer identity, with the aim of offering a practical example of how teacher-inquirer identity can be described in a single real case study. This objective pertains to the kind of study focused on identifying the characteristics of teacher identity (Beijaard, Meijer, & Verloop, 2004). More specifically, we want to offer a comprehensive overview of how the teacher experiences her inquirer teacher identity, the I-positions that make up her inquirer teacher identity and the types of relationships among I-positions that have been established within a process of educational change. We also want to identify the tensions and problems related to the various I-positions that appeared in the process of educational change.

### *Participants*

One teacher from a secondary school in Catalonia participated in this study. The teacher voluntarily agreed to participate after an explanation of the study in a meeting. The participant is a 39-year-old female with 17 years of teaching experience. She currently works as an English teacher. In addition, she has taken part to a moderate extent in some professional development activities over the past three years, including courses, workshops, conferences, visits to other schools and participation in professional development networks. The teacher was involved in a pedagogical innovation project that affects the entire school, consisting of the introduction of the cooperative learning methodology in all grades over a period of 12 months.

### *Data collection*

Data were collected during the period September-October 2019 by means of three instruments: a self-report (Hamman, Gosselin, Romano, & Bunuan, 2010), a card elicitation technique and an interview (Monereo, 2019). The self-report includes three sections. The items in the first section gathered personal information and data on the participant's academic background and professional experience. In the second section, the structured, open-ended format required each participant to describe seven (minimum) to ten (maximum) I-positions performed in school, all of them related to inquiry-based work regarding pedagogical innovation. The participant provided detailed information about the name of the position, the associated purpose of the function (what the teacher wanted to achieve in performing this position) and a typical inquiry task directly related to pedagogical innovation. Each I-position was described using a minimum of 100 words. The outcome of the self-report technique was a list of I-positions related to the teacher's inquiry-based work, as well as a detailed description of each I-position. We then wrote the names of each I-Position on a card (*Post-It*) and asked the participant to put the cards on a table in an organised manner and to talk about the relationship among the I-Positions. Finally, we asked the participant to describe any tensions and problems that had emerged within a pedagogical innovation process related to performing the identified I-positions.

### *Data analysis*

The data were analysed in three phases. First, the self-report was read thoroughly and divided into textual fragments. Each fragment includes all information referred to a single I-Position. Second, we took a picture of the original representation of the

configuration of the I-Positions, and we reconstructed some aspects of it that were not coherent with the explanation of the teacher. Finally, we summarised the teacher's statements and focused on those that provided the most relevant information about tensions and problems.

## **Results**

In adopting a comprehensive overview of her inquiry identity, the teacher revealed that the first purpose of her inquiry was connected to a school project to transform teaching practices in the school as a whole and more toward cooperative learning. This school transformation occurred as a negotiated process, wherein teachers could voice their personal purposes. The school's management team established this aim as highly relevant for the school and, consequently, they put in place enough resources to support it, with the positive consequence that the majority of teachers had a positive attitude about this pedagogical change, including our participant. As a starting point, the teachers were aware that they did not have the necessary conceptual and procedural knowledge about cooperative learning to apply the pedagogical innovation in their classrooms. All these aspects influenced the ultimate combination of I-Positions adopted by the teacher.

At the end of the pedagogical innovation, she reported that she could display her inquiry identity with a high level of ownership and agency, and with a very high degree of sense-making. One of the conditions that she identified as having influenced the sense-making process was the continuous mutual support between teachers throughout the innovation process. Nevertheless, the process of self-regulation applied over time made her aware of a need to acquire new knowledge and skills about inquiry processes, as well as to develop new I-Positions she had not considered initially.

The teacher identified 10 I-positions that make up her inquirer teacher identity when carrying out pedagogical innovation, and she described the relationship among them. Table 1 provides a list of the 10 I-Positions identified, and Figure 1 represents the combination of these I-Positions graphically.

Table 1. Ten I-Positions included in the teacher-inquirer identity of the single case-study.

---

1	To learn about cooperative learning
2	To collaborate with colleagues
3	To design a new lesson plan
4	To create new teaching materials
5	To implement pedagogical innovation in the classroom
6	To gather learning evidence
7	To assess pedagogical innovation
8	To share a pedagogical innovation
9	To revise previous teachers' knowledge
10	To communicate pedagogical innovation

---

Figure 1. A representation of the combination of the I-positions included in an inquirer identity of a specific teacher.

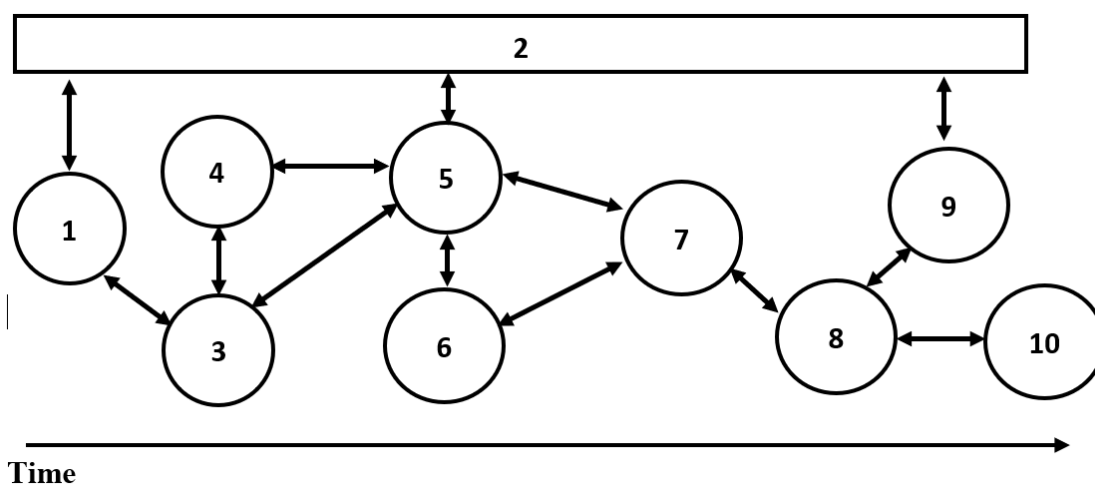

This combination of I-Positions reflects the way in which our teacher expressed her teacher-inquirer identity in the context of a pedagogical innovation over an entire year. All the I-Positions are chronologically organised, beginning with I-position 1 “To learn about cooperative learning”, which consisted of reviewing a set of publications about cooperative learning and working with a team to draft a “cooperative learning guide” for all the teachers at her school (Position 2: “To collaborate with colleagues”).

Using this conceptual and procedural knowledge, the teacher went on to design a lesson plan including cooperative learning as a teaching method (I-position 3: “To design a new lesson plan”) and to create related teaching materials (I-position 4: “To create new teaching materials”). As a result of these I-positions, the teacher was able to implement the lesson plan (I-position 5: “To implement pedagogical innovation in the classroom”), working collaboratively with a colleague (I-position 2). Meanwhile, the teacher

collected learning evidence related to cooperative learning (I-position 6: “To gather learning evidence”).

Data from the two previous I-positions allowed the teacher to assess this pedagogical innovation (I-Position 7: “to assess pedagogical innovation”). Finally, the teacher shared knowledge about the pedagogical innovation among other teachers at the same school (I-position 8: “To share the pedagogical innovation), revised previous teachers’ knowledge by modifying the initial “cooperative learning guide” making the second version of it (I-position 9: “To revise previous teachers’ knowledge”), and communicated the pedagogical innovation externally, to teachers at other schools (I-position 10: “To communicate pedagogical innovation”).

During the process of educational change, the teacher identified several relevant tensions and problems related to six I-positions. First, in carrying out I-position 2, the teacher faced a lot of problems with other teachers because they did not share enough knowledge about the topic of cooperative learning, and some of the other teachers had a negative attitude and an unfavourable I-position with regard to implementing this learning method (I-position 5). Second, the teacher reported feeling that she lacked sufficient knowledge to select proper pieces of evidence to reflect the extent to which cooperative learning had been successfully implemented (I-position 6). This initial lack of skills in that aspect had a significant impact on the practice of I-position 7 because the teacher was aware that she was not able to assess the pedagogical innovation accurately. Finally, the teacher became aware that two new I-positions had been required as part of this combination of I-positions related to teacher-inquirer identity. These I-positions are “To communicate the pedagogical innovation to families”, and “To collect the opinions of students about the pedagogical innovation”.

## **6. Conclusions and implications for research, teacher education and educational change**

This position paper has sought to offer a more comprehensive conceptualisation of the notion of *teacher-inquirer identity* using the dialogical self theory. To meet this objective, we provided a broad theoretical foundation of the notion of teacher inquiry, a set of the potential identity components of inquirer teacher and, more importantly, a

specific overview of the notion of teacher-inquirer identity, which we described as a combination of I-positions carried out during a pedagogical innovation.

In addition, we have presented the findings from a single case study in order to give a short methodological example of how research based on the case-study methodology about teacher-inquirer identity can be carried out using the dialogical self theory. Although the single case is presented as an example, we claim a certain degree of analytical generalizability of the results, because the case examined has broader empirical implications that point toward some of the deep principles and processes involved in the enactment of dialogical selves.

This kind of research in this area of study allows us to adopt a person-oriented approach (Vanthournout, 2011) to qualitative research. Unlike other research that adopts a variable-oriented approach, this research has made it possible to open the door to different ways of conducting qualitative research to answer alternative research questions. For example, while a variable-oriented approach is ideal for studying differences among groups of teachers involved in inquiry-based work using quantitative methodological techniques (Baan, Gaikhorst, Noordende, & Volman, 2019), a person-oriented approach using qualitative methodological techniques would allow us to identify differences among individual teachers by comparing their configuration of the inquirer identity I-positions, or by describing how teacher-inquirer identity may change over the course of a pedagogical innovation and identify the main factors that influence these changes.

Another possibility for future research consists of further examining the potential relationship between the notion of teacher-inquirer identity and three of the theoretical components of inquirer identity: *sense-making*, *agency* and *ownership*, as some contributions suggested that the three components do make a difference in the implementation of an educational innovation (Ketelaar, Beijaard, Den Brok, & Boshuizen, 2013). For example, existing research (Ketelaar et al., 2014) has revealed that a better understanding of the relationship among these three concepts could be useful for describing significant differences between teachers. In order to become an innovative teacher, it is necessary to have a high degree of both agency and ownership, but a moderate level of sense-making is sufficient. Other researches (Scribner et al.,



2007) have also revealed that if teachers in a professional community experience ownership, they take more responsibility, increasing the effectiveness of innovations.

Our application of a dialogical viewpoint on teacher-inquirer identity and our proposal to conduct new research on this concept is currently supported by only a limited number of empirical contributions. We are convinced that in the coming years, we will see substantial progress along this new research line, as evidenced by recent articles (Assen et al., 2018; Avidov-Ungar & Forkosh-Baruch, 2018).

The new academic knowledge which comes from this area of study of teacher-inquirer identity should inform teacher education and educational change policies because teacher-inquirer identity is at the core of professional growth and pedagogical transformation. This academic knowledge would be beneficial in the design and implementation of teacher education programs and courses aimed at developing inquiry competencies in teachers. Collecting information on a wide variety of configurations of inquiring teachers' I-Positions would help shape the contents of these programs and courses. A proven methodology for collecting data on a teacher's configuration inquiring I-Positions would be a useful way to evaluate the real impact of a teacher education program. Data could be gathered about the initial and the final configuration, and the results could be compared in order to identify real changes in teacher-inquirer identity.

This new academic knowledge in this area of study would also be useful for those wishing to plan more successful pedagogical innovations in schools. Research into teacher-inquirer identity will produce new insights related to how the components of teacher-inquirer identity and the relationship among them influence a teacher's favourable position with regard to educational change, whether a pedagogical innovation or, beyond that, steps toward educational reform.

Finally, we would like to underline that this new concept, which we have called teacher-inquirer identity, could grant us a new perspective on some issues closely related to teacher-inquirer identity. Some of these aspects that currently represent critical challenges to a number of well-developed educational systems, such as those in Canada, Finland and Singapore, include the design of research-based teacher education (Afdal &

Spernes, 2018) and the use of educational evidence to increase the quality of teaching and learning (Darling-Hammond, 2017).

## **Compliance with Ethical Standards**

### **Conflict of interest**

The authors declare that they have no conflict of interest.

### **Ethical Standards**

This position paper has been developed in accordance with the ethical standards of the American Psychological Association (2010). The participant was informed in advance of the general aim of the research, its duration, and the procedure to collect, store, and analyse the information provided by her. Following this notification, the participant freely decided to participate in this research. Data collected has been stored and managed observing the law on data protection and the right to confidentiality.

### **References**

- Afdal, H. W., & Spernes, K. (2018). Designing and redesigning research-based teacher education. *Teaching and Teacher Education, 74*, 215-228.
- Akkerman, S. F., & Meijer, P. C. (2011). A dialogical approach to conceptualizing teacher identity. *Teaching and Teacher Education, 27*(2), 308-319.
- Assen, J. H. E., Koops, H., Meijers, F., Otting, H., & Poell, R. F. (2018). How can a dialogue support teachers' professional identity development? Harmonising multiple teacher I-positions. *Teaching and Teacher Education, 73*, 130-140.
- Avidov-Ungar, O., & Forkosh-Baruch, A. (2018). Professional identity of teacher educators in the digital era in light of demands of pedagogical innovation. *Teaching and Teacher Education, 73*, 183-191.
- Baan, J., Gaikhorst, L., van't Noordende, J., & Volman, M. (2019). The involvement in inquiry-based working of teachers of research-intensive versus practically oriented teacher education programmes. *Teaching and Teacher Education, 84*, 74-82.
- Badia, A., & Iglesias, S. (2019). The science teacher identity and the use of technology in the classroom. *Journal of Science Education and Technology, 28*(5), 532-541.

- Beauchamp, C. & Thomas, L. (2009). Understanding teacher identity: an overview of issues in the literature and implications for teacher education. *Cambridge Journal of Education*, 39, 175-189.
- Beijaard, D., Meijer, P. C., & Verloop, N. (2004). Reconsidering research on teachers' professional identity. *Teaching and Teacher Education*, 20, 107–128.
- Beijaard, D., Verloop, N., & Vermunt, J. D. (2000). Teachers' perceptions of professional identity: An exploratory study from a personal knowledge perspective. *Teaching and Teacher Education*, 16(7), 749-764.
- Brause, R., & Mayher, J. (Eds.). (1991). *Search and re-search: What the inquiring teacher needs to know*. London: Falmer Press.
- Butler, D. L., & Schnellert, L. (2012). Collaborative inquiry in teacher professional development. *Teaching and Teacher Education*, 28(8), 1206-1220.
- Byman, R., Krokfors, L., Toom, A., Maaranen, K., Jyrhämä, R., Kynäslahti, H., & Kansanen, P. (2009). Educating inquiry-oriented teachers: students' attitudes and experiences towards research-based teacher education. *Educational Research and Evaluation*, 15(1), 79-92.
- Chua, B. L., Liu, W. C., & Chia, S. S. Y. (2018). Teacher identity, Professional Practice, and Inquiry (PPI) in teacher education. *Asia Pacific Journal of Education*, 38(4), 550-564.
- Cochran-Smith, M., & Lytle, S. L. (1999). Relationships of knowledge and practice: Teacher learning in communities. *Review of Research in Education*, 24(1), 249-305.
- Cochran-Smith, M., & Lytle, S. L. (2009). *Inquiry as stance. Practitioner research for the next generation*. New York: Teachers College Press.
- Darling-Hammond, L. (2017). Teacher education around the world: What can we learn from international practice?. *European Journal of Teacher Education*, 40(3), 291-309.
- Day, C. (1999). *Developing teachers: The challenges of lifelong learning*. London: Falmer Press.
- DeLuca, C., Bolden, B., & Chan, J. (2017). Systemic professional learning through collaborative inquiry: Examining teachers' perspectives. *Teaching and Teacher Education*, 67, 67-78.
- Dewey, J. (1986). How we think: A restatement of the relation of reflective thinking to the educative process. In J. A. Boydston (Ed.), *The later works of John Dewey*,

*Volume 8: 1933.* (pp. 105-352). Carbondale: Southern Illinois University Press.  
(Original work published 1933).

- Ermeling, B. A. (2010). Tracing the effects of teacher inquiry on classroom practice. *Teaching and Teacher Education*, 26(3), 377-388.
- Hamman, D., Gosselin, K., Romano, J., & Bunuan, R. (2010). Using possible-selves theory to understand the identity development of new teachers. *Teaching and Teacher Education*, 26(7), 1349-1361
- Hardy, I. (2016). In support of teachers' learning: Specifying and contextualising teacher inquiry as professional practice. *Asia-Pacific Journal of Teacher Education*, 44(1), 4-19.
- Hermans, H. J. (2001). The dialogical self: toward a theory of personal and cultural positioning. *Culture & Psychology*, 7(3), 243-281.
- Hermans, H. J. (2006). The self as a theater of voices: Disorganization and reorganization of a position repertoire. *Journal of Constructivist Psychology*, 19(2), 147-169.
- Hermans, H. J. (2015). Dialogical self in a complex world: the need for bridging theories. *Europe's Journal of Psychology*, 11(1), 1-4.
- Jyrhämä, R., Kynäslähti, H., Krokfors, L., Byman, R., Maaranen, K., Toom, A., & Kansanen, P. (2008). The appreciation and realisation of research-based teacher education: Finnish students' experiences of teacher education. *European Journal of Teacher Education*, 31(1), 1-16.
- Kaser, L., & Halbert, J. (2014). Creating and sustaining inquiry spaces for teacher learning and system transformation. *European Journal of Education*, 49(2), 206-217.
- Ketelaar, E., Beijaard, D., Den Brok, P. J., & Boshuizen, H. P. (2013). Teachers' implementation of the coaching role: do teachers' ownership, sensemaking, and agency make a difference?. *European Journal of Psychology of Education*, 28(3), 991-1006.
- Ketelaar, E.; Koopman, M.; Den Brok, P.; Beijaard, D & Boshuizen, H. (2014) Teachers' learning experiences in relation to their ownership, sense-making and agency. *Teachers and Teaching*, 20:3, 314-337.
- Konstantinidis, A. & Badia, A. (11-13 November, 2019). *The teacher inquirer identity during and educational innovation*. Seville (Spain). ICERI: International Conference of Education, Research and Innovation.

- Lasky, S. (2005). A sociocultural approach to understanding teacher identity, agency and professional vulnerability in a context of secondary school reform. *Teaching and Teacher Education*, 21(8), 899-916.
- Lunenberg, M., Ponte, P., & Van De Ven, P. H. (2007). Why shouldn't teachers and teacher educators conduct research on their own practices? An epistemological exploration. *European Educational Research Journal*, 6(1), 13-24.
- Meijers, F., & Hermans, H. (2018). Dialogical self theory in education: an introduction. In F. Meijers, & H. Hermans (Eds.), *The dialogical self theory in education* (pp. 1–17). New York: Springer.
- Mertler, C. A. (2012). *Action research. Improving schools and empowering educators*. Thousand Oaks, CA: Sage.
- Monereo, C. (2019). The role of critical incidents in the dialogical construction of teacher identity. Analysis of a professional transition case. *Learning, Culture and Social Interaction*, 20, 4-13.
- Pyhältö, K., Pietarinen, J., & Soini, T. (2018). Dynamic and shared sense-making in large-scale curriculum reform in school districts. *The Curriculum Journal*, 29(2), 181-200.
- Schaap, H., & de Bruijn, E. (2018). Elements affecting the development of professional learning communities in schools. *Learning Environments Research*, 21(1), 109-134.
- Schmidt, M., & Datnow, A. (2005). Teachers' sense-making about comprehensive school reform: The influence of emotions. *Teaching and Teacher Education*, 21(8), 949-965.
- Schön, D. (1991). *The reflective practitioner. How professionals think in action*. Aldershot, UK: Arena. (Original work published in 1983).
- Scribner, J. P., Sawyer, R. K., Watson, S. T., & Myers, V. L. (2007). Teacher teams and distributed leadership: A study of group discourse and collaboration. *Education Administration Quarterly*, 43, 67–100.
- Searle, J. (2010), *Making the social world: the structure of human civilization*. Oxford: Oxford University Press.
- Somekh, B., & Zeichner, K. (2009). Action research for educational reform: Remodelling action research theories and practices in local contexts. *Educational Action Research*, 17(1), 5-21.

- Stenberg, K., Karlsson, L., Pitkaniemi, H., & Maaranen, K. (2014). Beginning student teachers' teacher identities based on their practical theories. *European Journal of Teacher Education, 37*(2), 204-219.
- Taylor, L. A. (2017). How teachers become teacher researchers: Narrative as a tool for teacher identity construction. *Teaching and Teacher Education, 61*, 16-25.
- Timperley, H., Kaser, L., & Halbert, J. (2014). *A framework for transforming learning in schools: Innovation and the spiral of inquiry* (Vol. 234). Melbourne: Centre for Strategic Education.
- Vähäsantanen, K. (2015). Professional agency in the stream of change: Understanding educational change and teachers' professional identities. *Teaching and Teacher Education, 47*, 1-12.
- Vanhournout, G. (2011). *Patterns in student learning: exploring a person-oriented and a longitudinal research perspective*. Antwerp-Apeldoorn: Garant.
- Zeichner, K. M. (2003). Teacher research as professional development for P-12 educators in the USA. *Educational Action Research, 11*(2), 301-326.